

The Larches

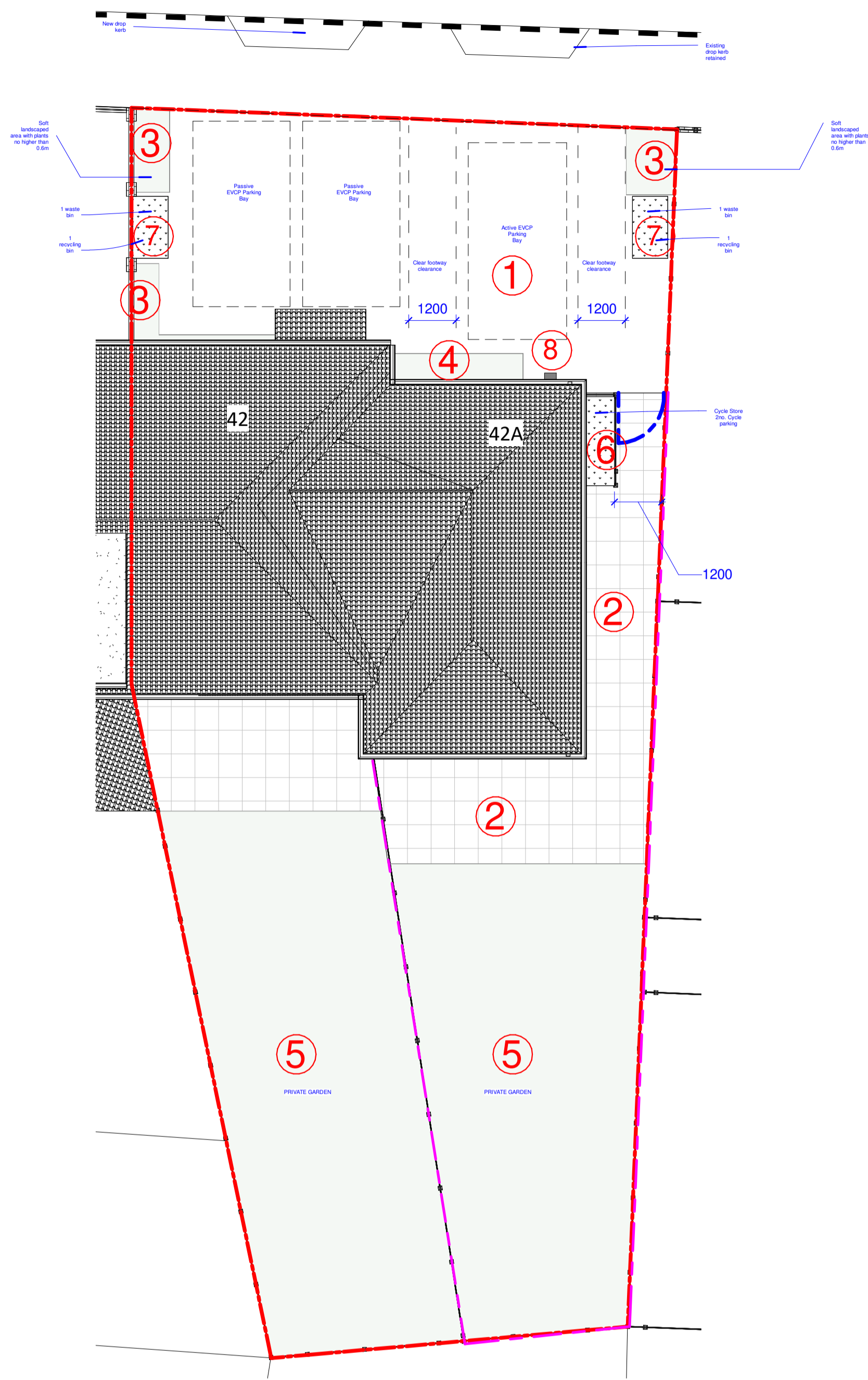

1 Landscape plan
1 : 100



Min. 1.8m HIGH TIMBER FENCE BETWEEN HOUSES



Min. 1.8m HIGH TIMBER FENCE BETWEEN HOUSES



1 CONCRETE PERMEABLE BLOCK PAVING TO FRONT DRIVEWAY, IN NATURAL COLOUR.



2 600x600 PAVING SLABS TO REAR PATIOS AND FOOTPATHS, IN NATURAL COLOUR.



3 LANDSCAPED PLANTER WITH NATIVE PLANTS



4 LANDSCAPED PLANTER WITH NATIVE PLANTS IN FRONT OF HOUSES

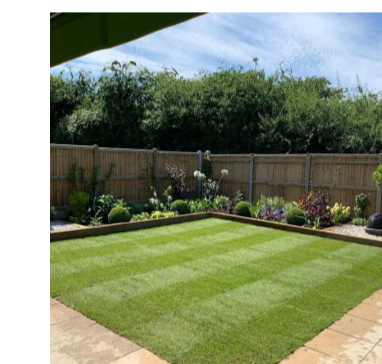

5 SHADE RESISTANT GRASS TO REAR LAWN

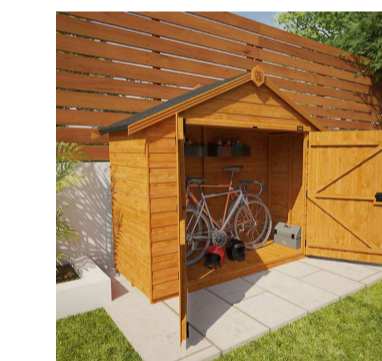

6 TIMBER PRIVATE BIKE SHED

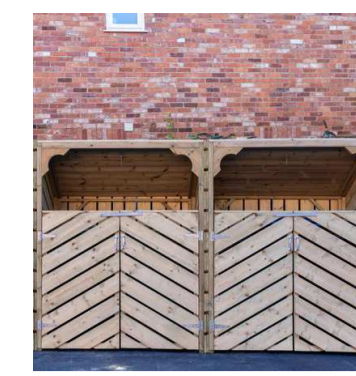

7 TIMBER BIN STORE WITH SEDUM ROOF



8 7kw active EVCP Easee One 7kW EV Charger Fixed to wall as indicated on plan

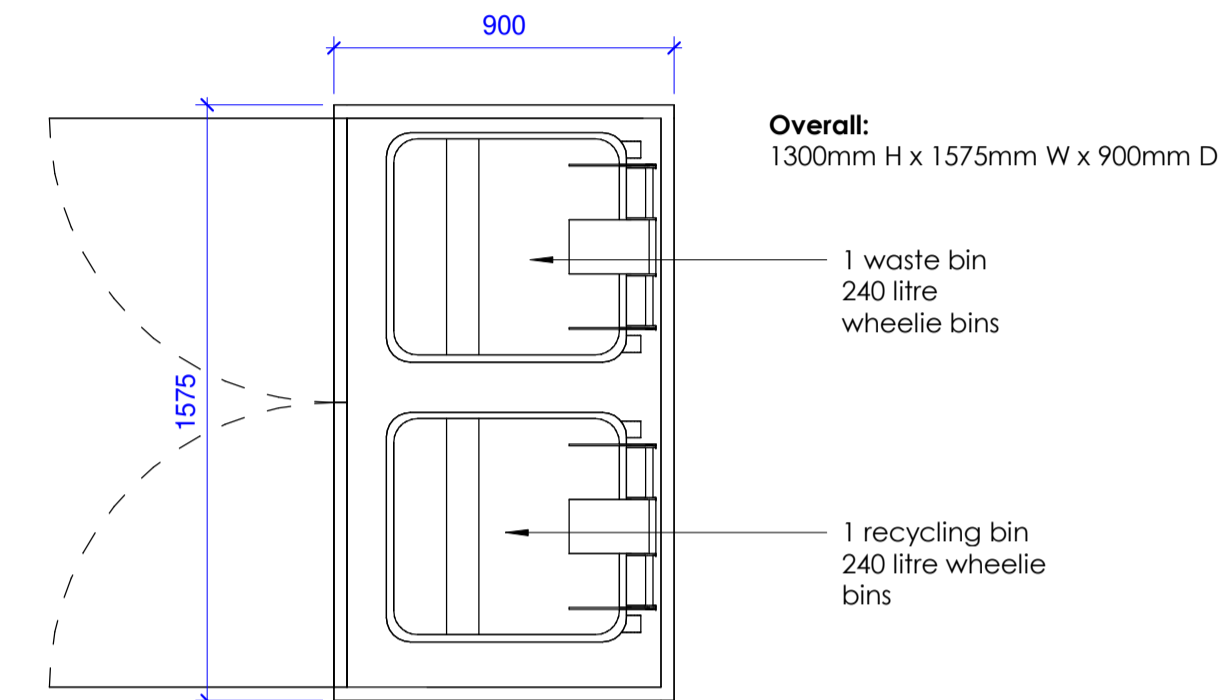

2 BIN STORE - PLAN
1 : 20

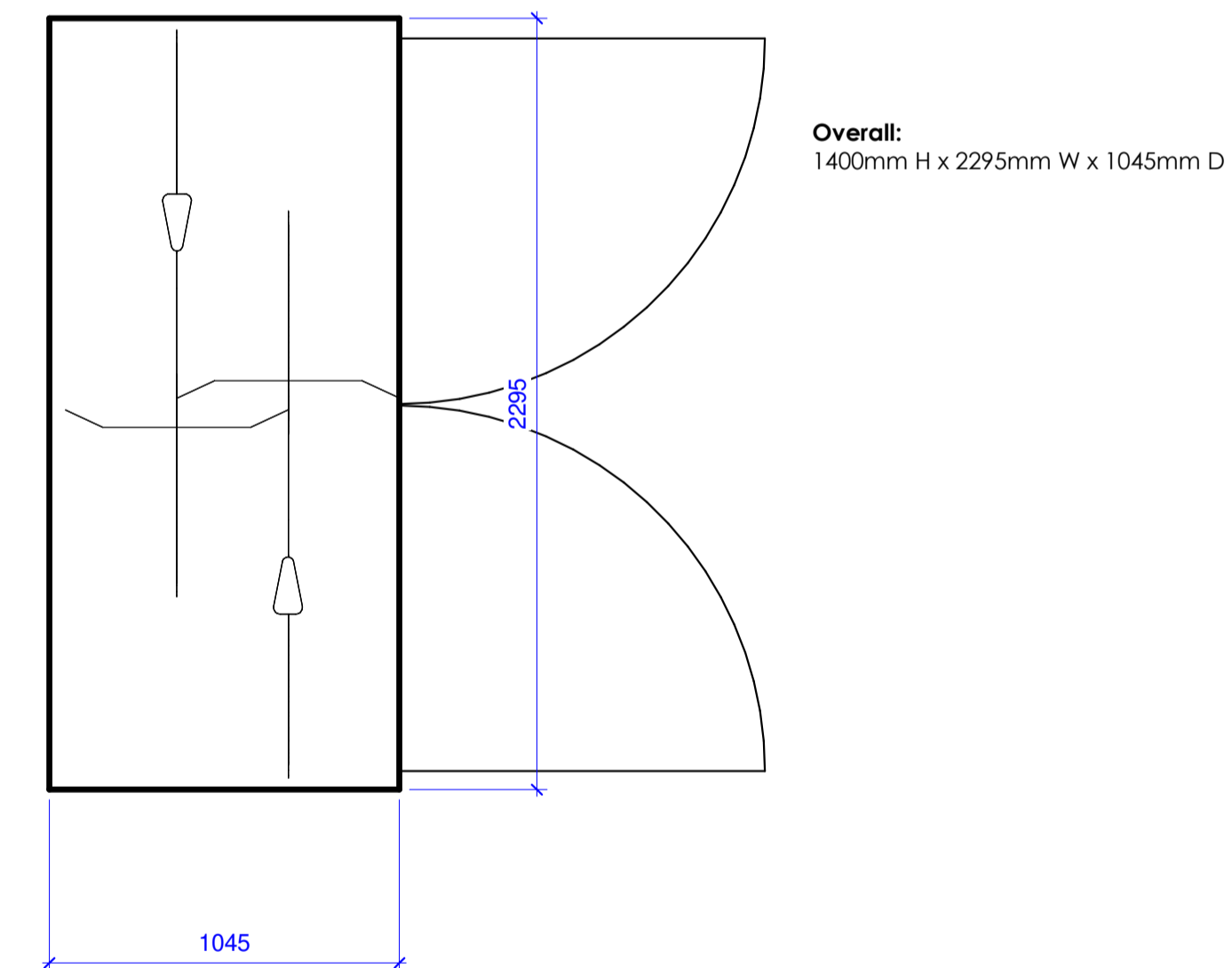

3 Cycle Store Plan
1 : 20

This drawing is protected under Copyright and at no time should any portion of this drawing be reproduced or copied without the permission of the Architect (Design Copyright Act 1988). This drawing must not be used for purposes other than that for which it was provided. It is supplied without liability for any errors or omissions. Drawings only to be scaled for planning application purposes, all dimensions to be checked on site. All drawings subject to Statutory Authority Approval.

Notes:

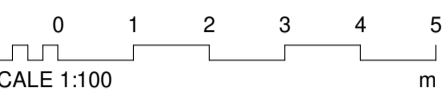

Rev	Description	Date	Drawn	Check
P01	Revised in line with comments	28/04/26	FS	FS



SMA STUDIO BARNET LTD

t 07908543268
e fadishawkat@smastudiobarnet.com

status: **Project Status**

project: **42 The Larches, Uxbridge**
E18 1P address here

drawing title: **LANDSCAPE PLAN**

date: **02/16/26** | scale: **As indicated**

dwg no: **ProjectA119** | rev no: **P01**
Number-