

01 - PROPOSED SITE PLAN SCALE 1:200



Zappi multiphase, car chargers With selectable power settings of 7kW and 22kW (6)



GRASS (3)



COVERED 2 CYCLES STORE (5)

UNIT 01- 3 BEDROOM- 4 PERSON DETACHED DWELLING

AREA SCHEDULE	
TYPE	AREA (GIA)
TOTAL COVERED AREA	113.5 sqm
PRIVATE AMENITY SPACE	145.0 sqm

UNIT 02- 3 BEDROOM- 4 PERSON DETACHED DWELLING

AREA SCHEDULE	
TYPE	AREA (GIA)
TOTAL COVERED AREA	113.5 sqm
PRIVATE AMENITY SPACE	175.0 sqm

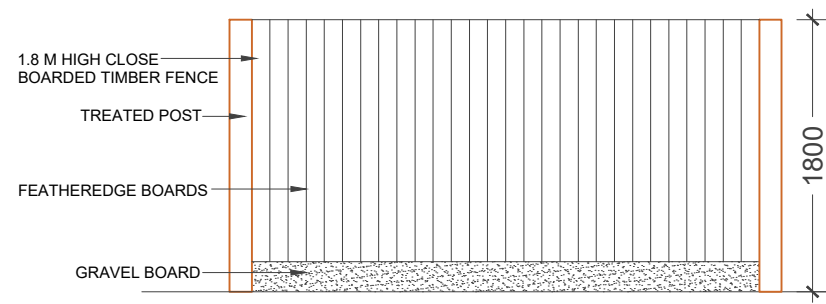

1.8 M HIGH CLOSE BOARDED TIMBER FENCE WITH REFERENCE IMAGE

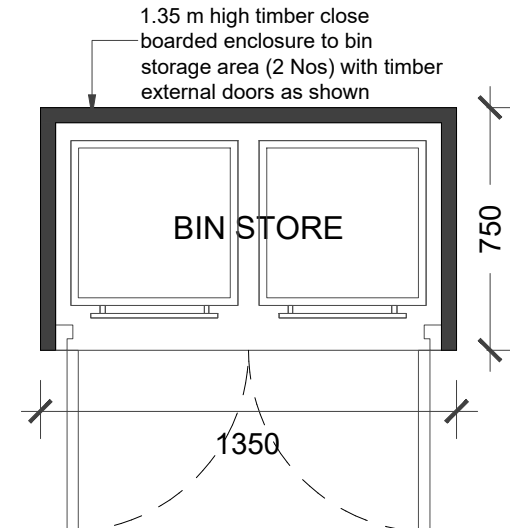

TYPICAL BIN STORAGE PLAN & ELEVATION 1:25

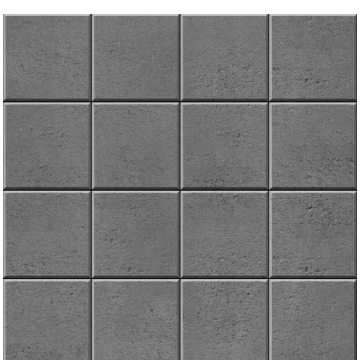
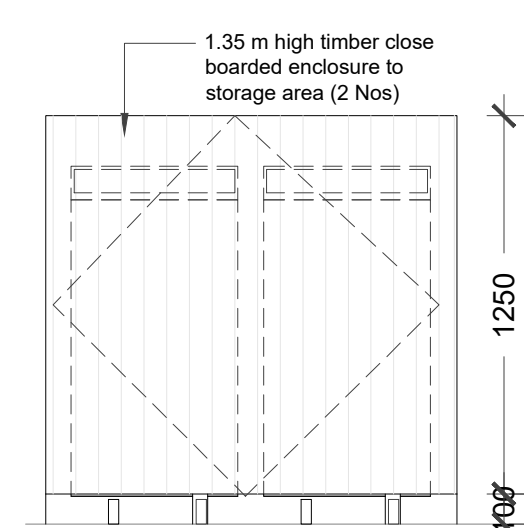

PERMEABLE PAVING AT PATIO (2)



PERMEABLE PAVING(1)

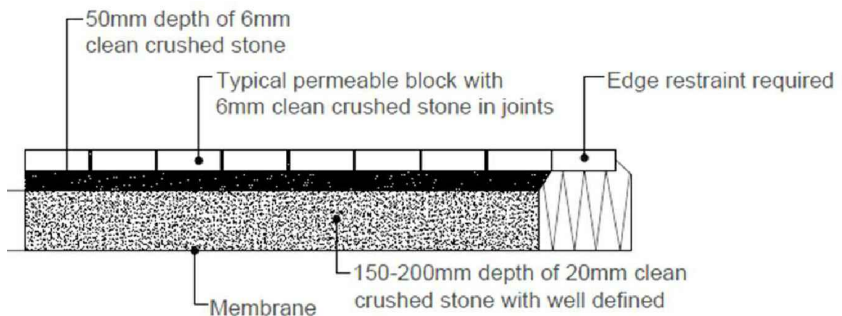

PAVING BUILT-UP DETAIL



COVERED BIN STORE (4)

REVISIONS			
NO	DESCRIPTION	DATE	BY

FULL PLANNING APPLICATION

DE ARCHITECTURAL CONSULT.LTD
M: 07824773079, 07869580774
E: design.endeavour@gmail.com

Project	9 ST. MARGARETS AVENUE LUXBRIDGE, UB8 3HH		
Title	PROPOSED SITE AND LANDSCAPE PLANS		
Scale	1:250@A3	Drawn	MU
Job No.	DAC-412/25	Approved	PF-9SM-06
Date	JAN-26		Rev.
			A