

Discharge of conditions

Condition 8

Site Address: 10 St Luke Close Cowley Uxbridge

Erection of two storey side extension and a single storey rear extension.
Roof light located on rear roof slope.
Creation of an additional 2xbed 4pers dwelling with associated amenities.
Demolition of existing outbuildings.

PREPARED BY
La Vaastu

10 St Lukes Close, Cowley, Uxbridge

This statement and accompanying documents/drawings are submitted in line with the Town and Country Planning Act 1990 (as amended) and the planning condition associated with the grant of planning application for Erection of two storey side extension and a single storey rear extension. Roof light located on rear roof slope. Creation of an additional 2xbed 4pers dwelling with associated amenities. Demolition of existing outbuildings at 10 St Luke Close Cowley Uxbridge

This submission is made in accordance with Condition 8 of planning permission 36391/APP/2023/2834, which states the following:

No development shall take place until a landscape scheme has been submitted to and approved in writing by the Local Planning Authority. The scheme shall include: -

1. Details of Soft Landscaping including privacy screening/buffering to ground floor front facing windows at no.10 St Luke Close
 - 1.a Planting plans (at not less than a scale of 1:100),
 - 1.b Written specification of planting and cultivation works to be undertaken,
 - 1.c Schedule of plants giving species, plant sizes, and proposed numbers/densities where appropriate
2. Details of Hard Landscaping
 - 2.a Means of enclosure/boundary treatments
 - 2.b Car Parking Layouts (including 2 electrical vehicle charging points)
3. Details of Landscape Maintenance
 - 3.a Landscape Maintenance Schedule for a minimum period of 5 years.
4. Details of cycle storage
 - 4.a Details of secured and covered bin storage including specification and location.
5. Schedule for Implementation

Thereafter the development shall be carried out and maintained in full accordance with the approved details.

1. Details of Soft Landscaping including privacy screening/buffering to ground floor front facing windows at no.10 St Luke Close

1.a Planting Plans (Scale 1:100)

A landscape plan at 1:100 scale is enclosed, illustrating the layout and positioning of all proposed soft landscaping elements. This includes front and rear gardens, boundary planting, and buffer zones.

1.b Specification of Planting and Cultivation Works

The planting works will be carried out using cultivated topsoil to a minimum depth of 300mm, with all planting beds mulched to 75mm using bark chippings. All planting will take place during the first suitable planting season (October to March) following site completion. Plants will be watered regularly until establishment and replaced if failed within the first 12 months.

1.c Schedule of Plants (Species, Sizes, Densities)

- Front garden and boundary:
 - Cherry Laurel hedge, 60–80cm high, 2 per linear metre



Cherry Laurel hedge

- Rear garden: As existing green lawn area.

2. Details of Hard Landscaping

- Front drive: Marshalls Driveline Piora Permeable paver blocks
 - Rear patio: Grey 20mm Porcelain Paving Slabs
- All hard surfaces will be SUDS-compliant to minimise surface runoff.



Marshalls Driveline Piora Permeable paving

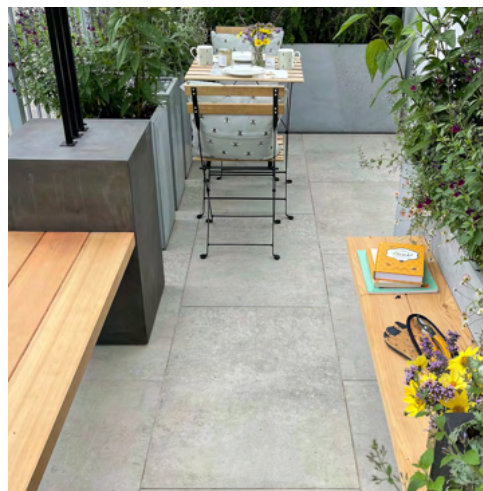

Grey 20mm Porcelain Paving Slabs

2.a Means of enclosure/boundary treatments

- Front boundary: As existing low Closeboard Fence Panels with Concrete Slotted Post
- Side and rear boundaries: part side and rear fence to be retained. New 1.8m close-boarded timber fencing with gravel board and concrete posts on side boundary.
- Access gates: Lockable side gate in timber to match fencing



close-boarded timber fencing

2.b Car Parking Layout (including 2 EV vehicle charging points)

- Two off-street parking spaces are proposed to the front, demarcated with permeable block paving
- an EVCP to be installed on both properties

Tech specs (7.4kW)

For more specifications please see our [data sheet](#).

Specifications	Tethered
Dimensions (HxWxD)	330mm x 290mm x 112mm
Weight	6kg
Connection type	Type 2
Compatibility	Type 2 compatible vehicles
Charging mode	Mode 3
Cable length	5m
Cable holster supplied	Yes
Lockable	Key lock sold separately
Socket type	Mennekes Type 2 (IEC 62196-2) socket with statutory locking mechanism
Wi-Fi	WPA, WPA2, WPA3 or Open Wi-Fi
IP Rating	IP54 enclosure (IP44/54 for plugs and socket)
IK Rating	IK10
Operating temperature	-25°C - 50°C
Protection	6mA DC Leakage, Over current, PME and failed earth protection.



EVC charger from Pod Point Electric Vehicle Charger Tethered Solo 3 7kW wall mounted

3. Details of Landscape Maintenance

3.a Landscape Maintenance Schedule for a minimum period of 5 years.

- **Soft landscaping works:** To be completed within the first planting season post-completion (Oct–Mar)
- **Hard landscaping and boundary treatments:** To be completed prior to first occupation
- **EV charging installation:** Completed prior to first occupation
- **Maintenance:** All landscaping will be maintained for five years post-installation, with any failed or dead planting replaced in the next available planting season

4. Details of cycle storage

A secure, timber cycle storage is provided in the rear garden for storage of two bikes.

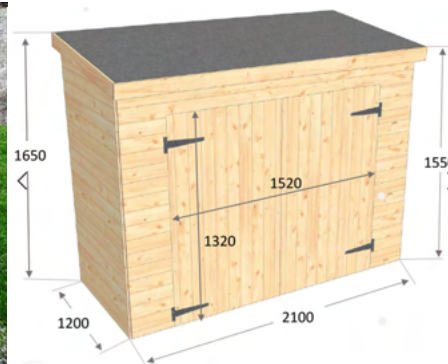

Timber Bike Shed (2100mm x 1200mm)

4.a Details of secured and covered bin storage including specification and location.

A secure, polypropylene refuse storage is provided to the front of the property with capacity for two 240L wheelie bins as shown in Landscape plan. This complies with LB Hillingdon’s waste storage design guidance.

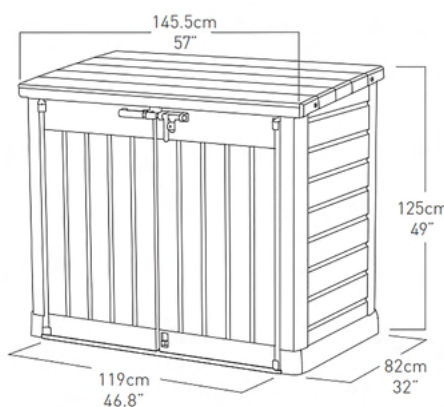

Refuse Storage from B&Q Keter Store It Out Max grey wood effect plastic 1200L

5. Schedule for Implementation

- 5.1 Refuse – timber refuse store for 2 wheely bins refer to drawing LaVaastu/2025/566/01
- 5.2 Cycle – Timber cycle store for 2 cycles refer to drawing LaVaastu/2025/566/01
- 5.3 Boundary – Existing front boundary to be retained, part side and rear existing fence to be retained, new timber fence to be installed, refer to drawing LaVaastu/2025/566/01
- 5.4 Hard Surfacing – New paving slabs to be installed to front drive and rear patio, refer to drawing LaVaastu/2025/566/01
- 5.5 Soft Landscaping – New lawn to be installed to front and rear landscaping area, refer to drawings LaVaastu/2025/566/01
- 5.6 Car Parking – an EVCP to be installed on both properties, refer to drawing LaVaastu/2025/566/01
- 5.7 All above works to be implemented during construction and prior to occupation.