

Riverside Way, Uxbridge – Tree Protection Method Statement

The tree protection method statement has been prepared in response to condition 4 of the consented development scheme at Riverside House, Riverside Way, Uxbridge UB8 2YF (application ref 35755/APP/2021/4136).

Prior to the commencement of any construction related activity including any demolition works, the tree protection measures detailed within the Tree Retention, Protection and Removal Plan (appended to this method statement) will be fully implemented by the Marbank site team.

The key personnel in facilitating the successful implementation of this scheme are:

Graeme Brand – Contracts Manager – graemebrand@marbank.co.uk

Jamie Murray – Construction Director – jamiemurray@marbank.co.uk

Where possible and existing ground conditions allow, the following protection barrier detail as defined in BS5837:2012 shall be used;

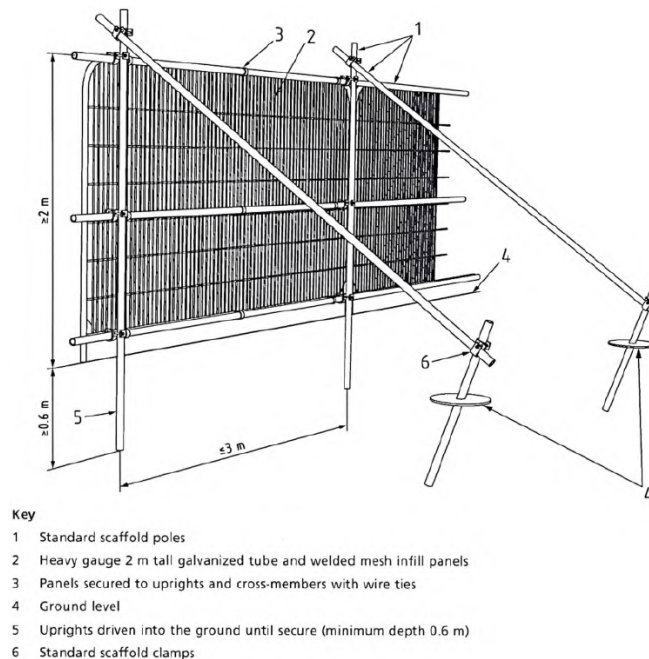

Where ground conditions do not facilitate the use of driven poles, the following alternative protection barrier detail as defined in BS5837:2012 shall be used;

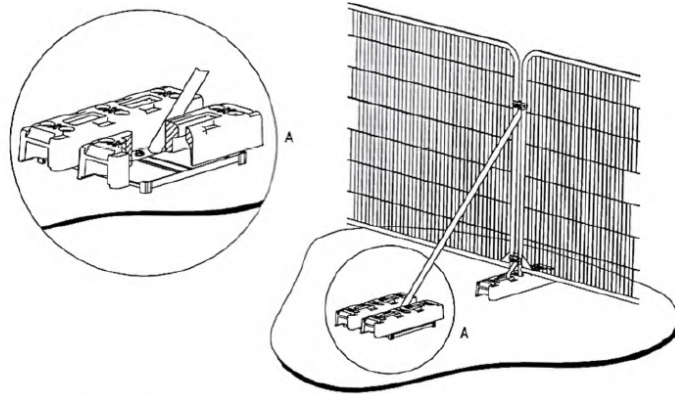

b) Stabilizer strut mounted on block tray

Waterproof signage will be affixed to the protection barrier at 10m intervals, with the wording facing the main construction activity stating “*Construction Exclusion Zone – Keep Out*”



Regular monitoring of the protection barriers will be undertaken by the Marbank site manager, on a daily basis, and form part of a recorded weekly site inspection to ensure the exclusion zone is kept in an acceptable condition throughout all stages of the construction project.

The site is subject to a no fires policy, and as such no fires shall be lit within or in proximity to any protected areas.

No oils, fuels or chemicals will be stored within 15m of the barrier fencing in order to protect the soils of the protected zone. All storage will be bunded in any case to prevent other contamination events. Washing out of concrete deliveries will be undertaken in a skip and at least 15m from the protected zone.

Site welfare cabins will be positioned to avoid the protected zone.

No temporary service connections shall encroach the protected zone.

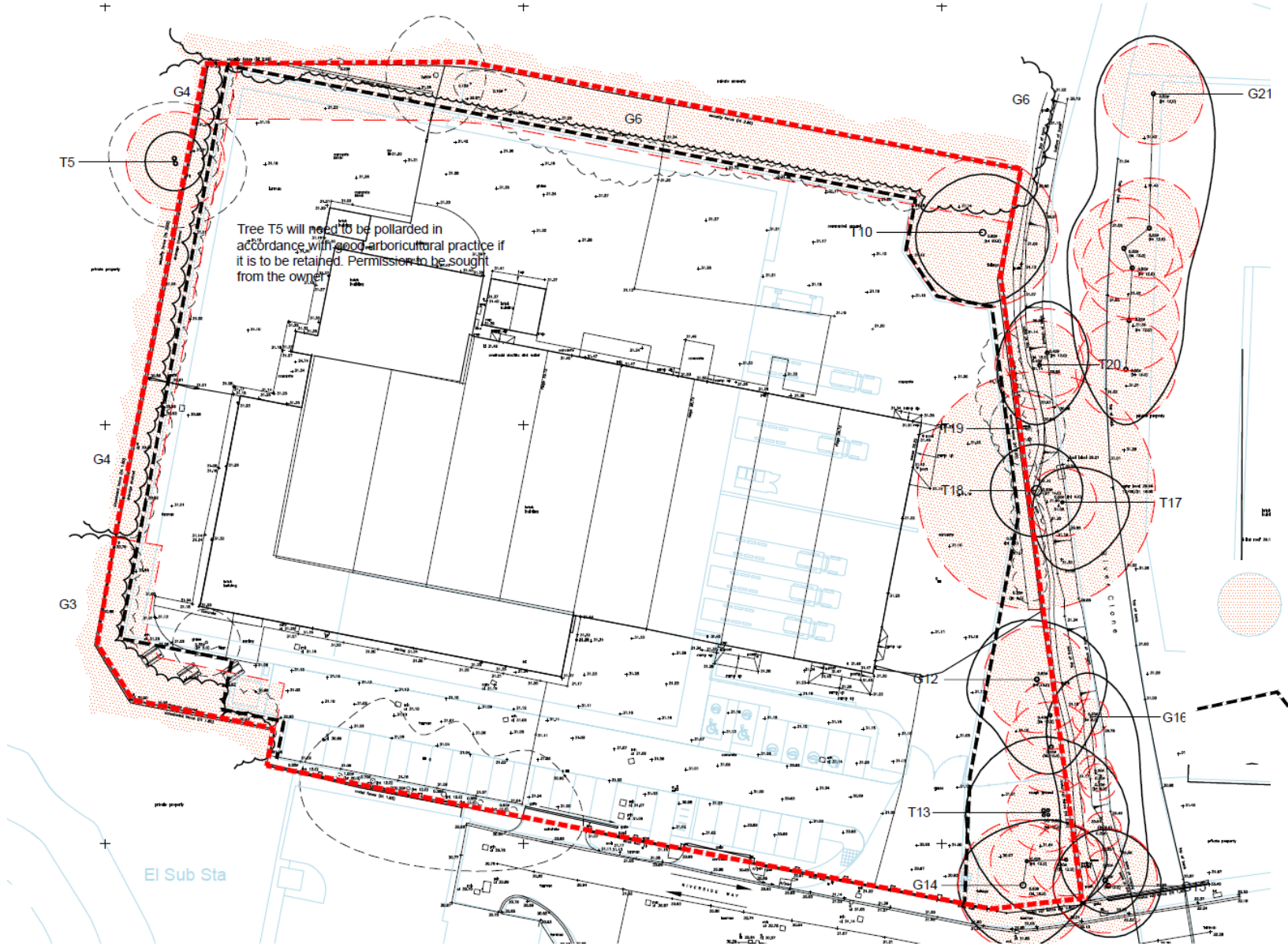

ROOT PROTECTION ZONE: Area of hatching around protected trees indicates the minimum Root Protection Area required in accordance with the BB Trees Ltd Pre Development Tree Survey dated October 2021.

PROTECTIVE BARRIER: Existing trees to be retained shall be protected by protective barrier erected in accordance with the specification figure 2 of BS5837:2012. Barrier to be erected on the edge of the root protection area for each tree to be protected. To be erected prior to the commencement of any construction works on site.