

Mark	Revision	Date	Drawn	Chkd	Appd
A	REVISED LAYOUT	17.05.17	RC	GS	

SCALING NOTE: Do not scale from this drawing. If in doubt, ask.  
 UTILITIES NOTE: The position of any existing public or private sewers, utility services, plant or apparatus shown on this drawing is believed to be correct, but no warranty to this is expressed or implied. Other such plant or apparatus may also be present but not shown. The Contractor is therefore advised to undertake his own investigation where the presence of any existing sewers, services, plant or apparatus may affect his operations.

Drawing Issue Status: **FOR PLANNING**

**NESTLES AVENUE, HAYES  
 PROPOSED SITE LAYOUT  
 SWEPT PATH ANALYSIS  
 16.5m ARTICULATED VEHICLE INBOUND**

Client: **SEGRO**

Date of 1st Issue: 23.01.17  
 Designed: -  
 Drawn: RC

A1 Scale: 1:500  
 Checked: SM  
 Approved: SM

Drawing Number: **30710-001-PL01**  
 Revision: **A**

**pba peterbrett**  
 Offices throughout the UK and Europe  
 www.peterbrett.com  
 © Peter Brett Associates LLP  
 READING  
 Tel: 0118 950 0761

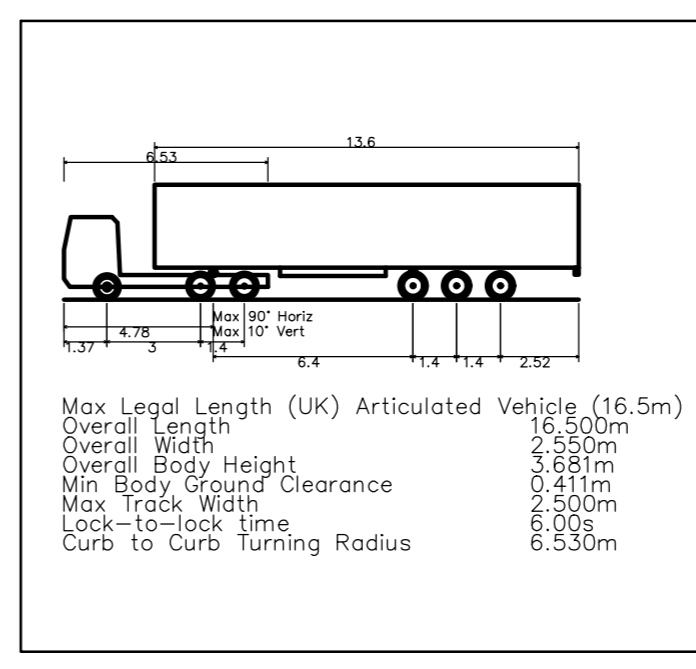

Mark	Revision	Date	Drawn	Chkd	Appd
A	REVISED LAYOUT	17.05.17	RC	GS	

SCALING NOTE: Do not scale from this drawing. If in doubt, ask.  
 UTILITIES NOTE: The position of any existing public or private sewers, utility services, plant or apparatus shown on this drawing is believed to be correct, but no warranty to this is expressed or implied. Other such plant or apparatus may also be present but not shown. The Contractor is therefore advised to undertake his own investigation where the presence of any existing sewers, services, plant or apparatus may affect his operations.

Drawing Issue Status  
**FOR PLANNING**  
 NESTLES AVENUE, HAYES  
 PROPOSED SITE LAYOUT  
 SWEPT PATH ANALYSIS  
 16.5m ARTICULATED VEHICLE OUTBOUND

Client

**SEGRO**

**pba peterbrett**  
 Offices throughout the UK and Europe  
 www.peterbrett.com  
 © Peter Brett Associates LLP  
 READING  
 Tel: 0118 950 0761

Date of 1st Issue	Designed	Drawn
23.01.17	-	RC
A1 Scale	Checked	Approved
1:500	SM	SM
Drawing Number	Revision	
30710-001-PL02	A	